

**3.44 IN./135MM
 TORPEDO DIA.**

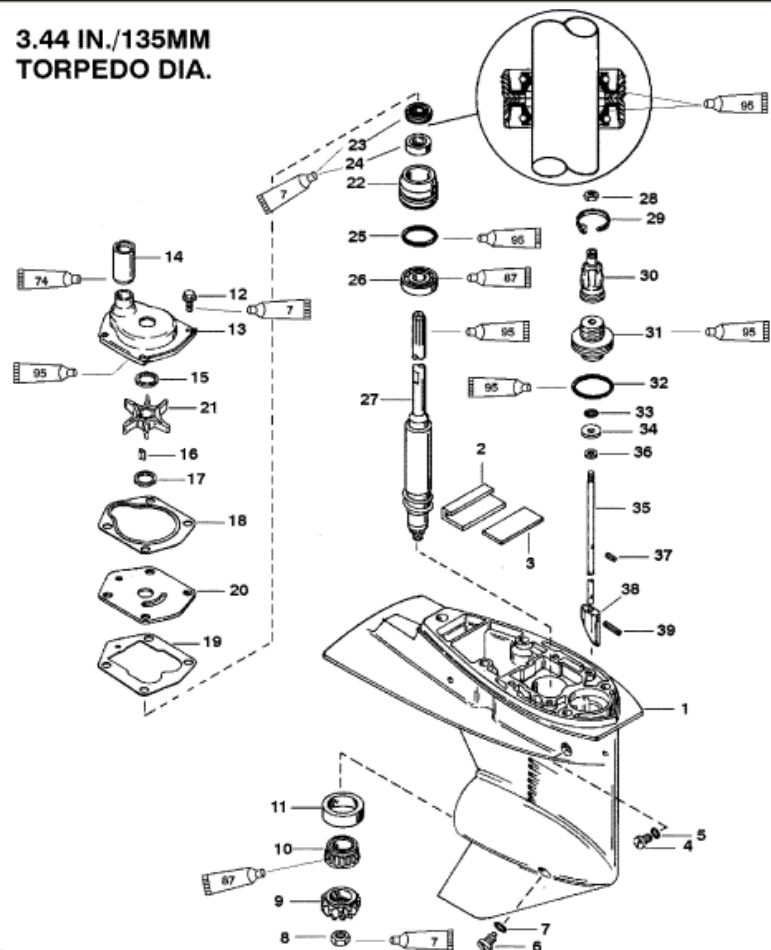

- Loctite *271* Adhesive Sealant (92-809819)
- Loctite *405* (Purchase Locally)
- Super Duty Gear Lubricant (92-13783A24)
- 2-4-C w/Teflon (92-825407A12)

Parts List						
Ref	Class	Part	Description	Qty	Comment	Footnote
-	1682	821306A26	GEAR HOUSING	1	(BLACK) SHORT	
-	1682	821306A27	GEAR HOUSING	1	(GRAY) SHORT	
-	1682	821306A28	GEAR HOUSING	1	(BLACK) LONG	
-	1682	821306A29	GEAR HOUSING	1	(GRAY) LONG	
1	1682	821306A12	GEAR HOUSING	1	(BASIC-BLACK)	
1	1682	821306A13	GEAR HOUSING]	1	(BASIC-GRAY)	
2		818226A	SEAL/PLATE KIT	1		
3		NSS	PLATE	1		4
4	10	79953A 2	SCREW (.375-16 X .25)	1		
5	12	19183	WASHER-SEALING	1		1
6	22	67892A 1	DRAIN SCREW (MAGNETIC)	1		
7	12	19183	WASHER-SEALING	1		1
8	11	55910	NUT	1		
9	43	822161 2	PINION GEAR (12 TEETH)	1		3
10	31	821321A 2	BEARING ASSEMBLY-ROLLER	1		
11		NSS	CUP	1		4
12	10	824832 4	SCREW (M6 X 16)	4		
13	46	821351A 3	WATER PUMP UPPER HOUSIN	1		3
14		823547 1	SEAL-WATER TUBE	1		5,6
15	12	86645 1	WASHER	1		1,6,5
16	28	85119	KEY	1		5,6
17	12	86645 1	WASHER	1		1,6,5
18	27	822189	GASKET	1		1,6,5
19	27	822217	GASKET (LOWER)	1		1,6,5
20		821354 2	FACE PLATE	1		6
21	47	85089 3	IMPELLER	1		6
22	46	821307A 2	WATER PUMP BASE ASSEMBL	1		
23	26	821309	SEAL-OIL	1		5
24	26	821310	SEAL-OIL	1		5
25	25	821308	O RING	1		1,5
26	30	821311	BALL BEARING	1		
27	45	822466A 1	DRIVESHAFT	1	(SHORT)	
27	45	822159A 1	DRIVESHAFT	1	(LONG)	
28	11	40021 2	NUT	1	(INCLUDED WITH REF #35)	
29		823548	CABLE TIE	1		5
30		822158	BOOT-SHIFT SHAFT	1		5
31		821827	RETAINER-SHIFT SHAFT	1		
32	25	26855	O RING	1		1,5
33	25	85594	O RING	1		1,5
34	12	814803	WASHER	1		
35		822452A 1	SHIFT SHAFT	1	(SHORT)	